

L-708 / L-708LD Bore Alignment System

Aligning Bores is
Now Faster and
Easier Than Ever



L-708 / L-708LD

Laser Bore Alignment System

The Leader in Laser Bore Alignment Technology

Hamar Laser manufactures the most accurate, versatile and portable bore alignment laser system available: The L-708 Standard and L-708LD Long Distance Bore Lasers.

Data taking targets include: self-centering, see-through, 2-axis and 4-axis targets with hand-held readouts, and Windows-based software to display and analyze alignment data in real time.

Bore applications include:

- Engine Blocks
- Compressor Bores
- Shaft Bearing Bores
- Stern Tubes
- Plus many more

Results 3x Faster Than Optical Bore Scopes or Tight Wire

With the L-708 / L-708LD, alignment of bores is fast and easy: Setup takes 15 to 20 minutes, and overall alignments are done up to 3x faster than with optical bore scopes or tight wire. Because alignment data is real time, misaligned bores can be brought into tolerance very quickly. After setup, a 10' (3 M) long bore can be measured for straightness every foot (300 mm) in under 5 minutes!

Self-Centering Target Adapters Reduces Setup time by 50%

With conventional bore alignment methods, the measuring device is typically mounted outside the bores, and targets are used in reference bores to align the measurement

system — a very cumbersome process that can easily take an hour, or more. With Hamar Laser's patented, self-centering target adapter technology, the setup process is simple: Use the A-514GS or A-514GL Leg Setting Gage to set the legs to the desired diameter. Then the laser and target are mounted directly into the reference bores, reducing setup time to just minutes.

More Accurate and Repeatable Measurements Than Optics

With optics, the measurement process can be more of an "art" than a science, since one operator will "see" a different set of values than another. The L-708 systems use sophisticated electronic sensors to detect the laser and thus offer greater accuracy and repeatability. Bores can be aligned to .0006" (0.015 mm) and the results are repeatable to .0002" (.005 mm). For high accuracy bore applications, the laser should be mounted externally, using the L-111 Laser Stand with the L-102 Beam Translator which can produce accuracies down to .0002" (0.005 mm).

Extend Component Life, Reduce Downtime

Misaligned bearing bores will cause premature failures, requiring frequent replacement, more downtime, and higher maintenance costs. Proper and more accurate alignment helps components to last longer and prevent big problems — before they occur.

Key Features:

- Adaptable to most bore applications
- Fast, easy setup using simple self-centering adapters
- Setup and start capturing alignment data in under 20 minutes
- Check alignment for bore diameters from 3.5" (86 mm) to 40"+ (1 M)
- Adjustable legs will fit a large range of bore diameters
- Leg Setting Gage centers adapters to .0003" (.0075 mm)
- Readouts update in real time as the bore is adjusted
- Choice of standard LED readout, or add a second readout to transmit readings wirelessly up to 200' (61 M)
- L-708 Operational Range: 100' (30.5 M)
L-708LD Operational Range: 200' (61 M)
- Durable and rugged design



Hamar's patented, self-centering A-514 Target Adapters speed the alignment process, and use adjustable legs for different sized bores.

Features Designed With Versatility in Mind

Self-Centering Adapters — The Key to Speed

The A-512 Target and A-514 Adapter Hubs are designed so that the PSD (position sensing detector) is centered axially between the adapter's four feet, two of which are offset axially from the other two feet. This puts the PSD on the pivot point of the adapter and allows the target's angle of incidence to the laser to vary by up to 45° without changing the adapter's centering. To insert the target/adapter into the bore, a weighted handle is attached to the target/adapter and the adapter is tipped forward, which allows it to be inserted into the bore. The weight of the handle forces the target to tip backward and seat the target legs into the bore, centering the adapter/target.

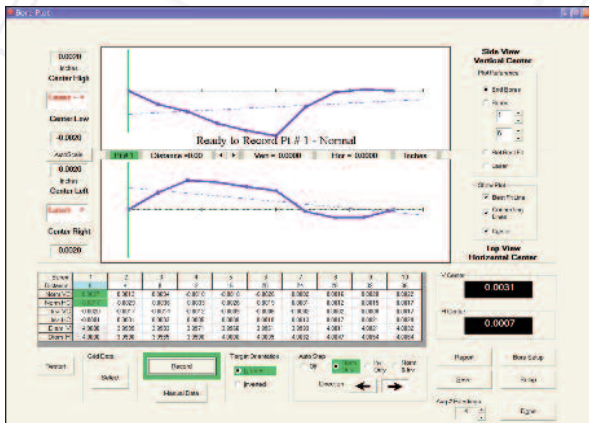
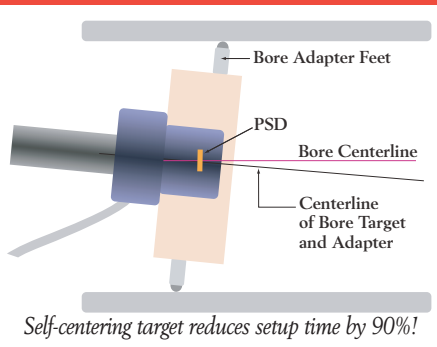

Bore8 Software showing plot of bore straightness.

Self-Centering Laser/Adapters

Our patented A-514 self-centering laser and target bore adapters accurately and quickly position the laser and target on the bore centerline. The adapters can be centered to the bore to within .0003" (.0075 mm).

Adjustable Target Adapter Legs

Self-centering laser and target adapters have adjustable legs that allow adapters to be used for diameters ranging from 3.5" (86 mm) to 40" (1 M). Choose from three bore adapters: A-514A for bores from 3.5" (90 mm) to 6.5" (165.1 mm), A-514B for bores from 6" (152.4 mm) to 18" (457.2 mm) and the A-514C for bores from 17" (435 mm) to 40" (1 M).

Long Range, High Accuracy

The L-708LD can be used out to 200' (61 M). Laser beam is straight to 0.0008 mm/M.

Precise Angular Adjustment

Precision angular adjustments provide angular pointing control of the laser beam so it can be tilted with a resolution of .0007" in 100' (0.018 mm in 30.5 M). The L-708LD laser has an angular adjustment resolution of .0014" in 200' (0.036 mm in 61 M).

Large Bore, Half Bore and See-Through Applications

For bores over 1 meter, half-bores, or where bore surfaces are worn or rough, the T-218 Two-Axis

Universal Target and T-225L Large Bore Flange are used. The T-218 has a prism that flips out of the way, allowing the laser beam to pass unobstructed through the target without removing it — a useful feature when aligning multiple bores over long distances. For half-bores, the T-218 is used with our A-502A Half-Bore and A-501A Bore Sweep Fixtures.

Large-Range Targets

For 200-foot measuring range, the L-708LD Long Distance Bore laser requires a larger-diameter laser beam, which requires our large-range bore target, the T-1218 2-Axis Target. It has 20 x 20 mm measuring range and has a hardened, stainless steel body with a 3" (76.2 mm) diameter mounting surface. Use with the T-1225L Bore Adapter to measure bores from 4.5" (114.3 mm) to 40"+(1 M).

Laser Beam Concentric to Mounting OD

The L-708 laser beam is concentric to its 1.2495" (31.74 mm) OD mounting surface to 0.0003" (0.008 mm). The face of the laser has powerful magnets to hold the laser in the adapters.

Optional Computer Upgrade

Data can be collected and displayed in real time with laptop upgrade and Bore8 Software that plots bore misalignment: 1) relative to end bores, 2) relative to two user-defined bores or 3) relative to Best Fit line.

How HLI Bore Alignment Systems Work

Two Ways to Mount the Laser

1. Internal Mount

This method allows centering to .0006" (0.015 mm). The A-514 Self-Centering Bore Adapters for both laser and target are put on a leg-setting gage to adjust the legs to the desired bore radius. Next the L-708 and A-512 Targets are inserted into their bore adapters. The laser and target assemblies are inserted into the two reference bores where they self-center. Then the laser's angular adjustments are used to set/tilt the laser to zero on the target, establishing the reference bore centerline. The target can be moved (or second target added) to inner bores for alignment checks. Since the alignment data in the readout updates in real time, any errors can be adjusted using the target as a live indicator.



Using the A-514 Self-Centering Target Adapters, the L-708 can be mounted in the first reference bore and centered to .0006" (0.015 mm).

2. External Mount

For higher accuracy applications, where alignment of the bores (not straightness) is needed, mounting the laser externally is recommended. This method produces a more accurate laser centering to .0002" (0.005 mm).

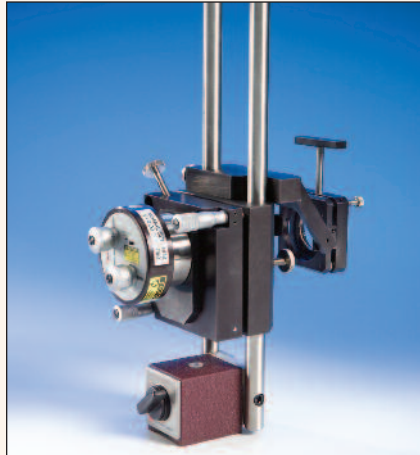

L-708, L-111 Laser Stand, L-102 Beam Translator

The L-111 Laser Stand has coarse angular adjustment and the L-102 Beam Translator can move the laser beam up/down and left/right without changing the angle. The L-708 is mounted in the L-111 and the L-102 is attached. The whole assembly is then mounted near the first reference bore. The A-512/A-514 target/adaptor is placed in the first bore and the L-102 is adjusted to center the beam to the target. The target is then moved to the far reference bore and the angular adjustments are used to tilt the laser to the center of the target. This process is repeated a few times until the target reads zero at both locations.

Measuring Bore Alignment

After setup, the A-512 Target is placed in the desired bore for measurement, which takes <10 seconds. The R-1307 2-Axis Readout displays bore misalignment. To align a bore to a centerline, two sets of readings are needed: one in the front and one in the rear of the bore. This aligns the angle of the bore as well as its center to the reference bore centerline.

High-Tolerance Bore Alignment

For high-tolerance bore applications, the Target Sensor Concentricity Error (TSCE) must be calculated using a procedure called the NORMIN method. The TSCE is calculated by taking two readings, one with the target at the normal (12:00) position and a second with the target inverted (6:00). The second reading is subtracted from the first and the result is divided by two to determine the TSCE. The TSCE can be subtracted from all subsequent bore measurements to produce the true misalignment value. Our Bore8 software can easily calculate TSCE and even automatically remove it from the displayed reading.

Checking Bore Straightness on Cylinders up to 25' Long

Checking the bore straightness of a long cylinder is a simple procedure. After setting up the laser, the target is inserted into the bore in predetermined increments and the readings are recorded. For long bores, the A-512 Target uses a pole to push the target into each measuring point up to 25' (7.6 M) inside a bore.

Alignment Solutions for Even the Most Difficult Bore Applications

Applications Overview

Hamar Laser bore systems can handle a wide range of bore alignment and straightness determination and measurement tasks. Even extremely difficult bore alignment challenges, like spherical bearings, can be done easily. If you do not see your application listed, please contact us to discuss your requirements. We will be more than happy to provide a solution that's right for your unique alignment problem.

Automotive, Marine & Locomotive Engine Blocks

- Crankshaft and camshaft line bores
- Cylinder straightness

Manufacturing & Metalworking

- Boring bar bearing alignment
- Deep bore straightness checks on parts
- Workpiece bore to spindle alignment

Marine

- Propeller shaft bearing bores
- Stern tube alignment

Power Generation

- Steam turbines
- Gas turbines

Plastics

- Extruder barrel alignment
- Extruder bore straightness and wear

Aerospace

- Hinge line spherical bearing bores

Stern Tube & Propeller Shaft Bearings

The L-708 / L-708LD can quickly and easily check stern tube and propeller shaft bearing alignment. It can even check the gearbox shaft's axis of rotation alignment to its bearings, saving loads of time versus a tight wire. It can also be used to set up boring bar bearings for line boring equipment.

Engine Block Bore Alignment

The L-708 / L-708LD gives automotive and diesel-engine manufacturers a fast, reliable way to measure crankshaft bores for straightness and alignment. Our system decreases inspection times significantly and eliminates the need for expensive gauging. The L-708 / L-708LD is also used for measuring the straightness of engine block cylinder bores.

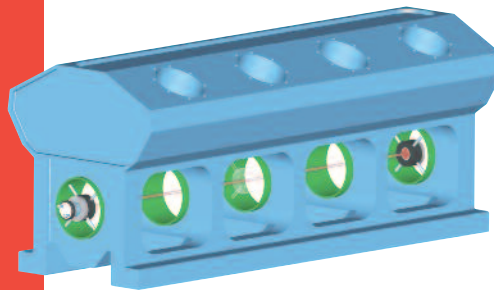

Engine block crankshaft bearing bore alignment.

Extruder Barrel Alignment

With a 10 minute setup time and simple procedure, extruder barrels can be aligned in less than 1 hour using our L-705 Bore Laser. The adapters can also be used to measure barrel wear.

Turbine Alignment

Since 1975, our Steam Turbine Alignment System has cut alignment times by 50% and increased accuracy vs. tight wires. With the introduction of the L-705, alignment times have been further reduced. We also offer lasers to check split joint flatness and motor couplings.

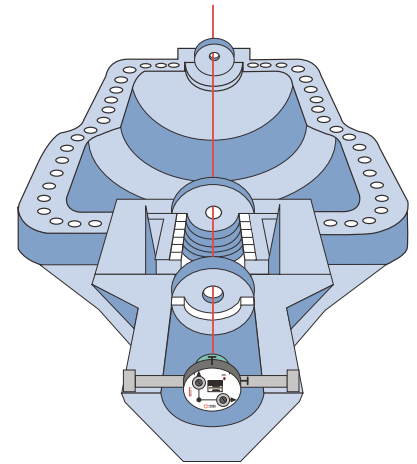

The L-706 Laser is designed for use over long distances making it suitable for steam turbine alignment applications.

Hinge-Line Bearing Alignment

Smaller spherical bearings in commercial aircraft hinge-lines are aligned using the L-705 and T-271 2-Axis Virtual Center Target. For larger spherical bearings (2.25" and above) the T-218 Target and T-225X Flange are used. Now extremely difficult alignment tasks can be done in one-tenth the time!

Specifications

Target and Bore Adapters

- A-512 Target** Mounting Surface OD: 1.1870" (30.15 mm). Target sensor concentric to OD to within .0003" (0.008 mm). Mounting surface 303 SS.
- A-514A Small Bore Target Adapter** For bore diameters from 3.5" (88.9 mm) to 6.5" (165.1 mm).
- A-514B Medium Bore Target Adapter** For bore diameters from 6" (152.4 mm) to 18" (457.2 mm).
- A-514C Large Bore Target Adapter** For bore diameters from 17" (431.8 mm) to 40" (1 M).
- A-514G Bore Gage** Sets A-514 Adapters legs to correct bore diameter to .0002" (.005 mm). Use A-514GS for A-514A & B Adapters. Use A-514GL for A-514A, B & C Adapters.

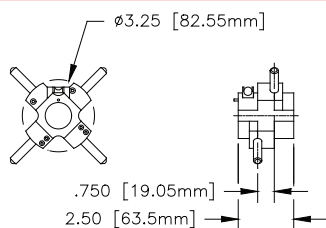

A-514A Target Adapter

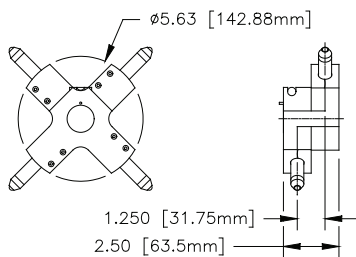

A-514B Target Adapter

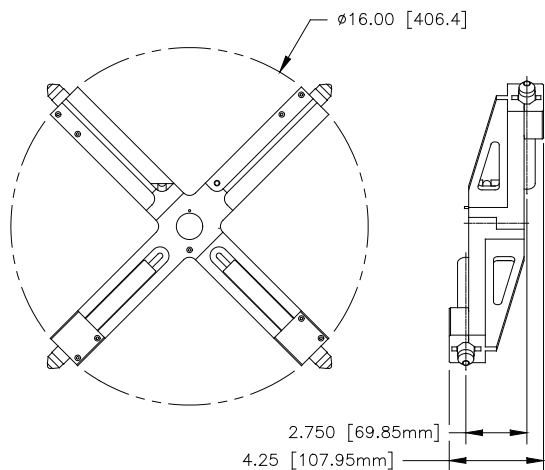

A-514C Target Adapter

L-708 / L-708LD Laser

- Size** (See line drawings)
- Weight** 1.6 lbs. (0.7 kg.)
- Power** 9V external battery pack/AC adapter
- Center** Laser concentric within .0003" (0.008 mm)
No adjustment
- Angular Adj. Resolution** Controlled by two high-pitch adjustment knobs.
Coarse: .0006"/ft. (0.05 mm/M)
Fine: .000007"/ft. (0.0006 mm/M)
- Angular Adj. Range** Coarse: $\pm 1.0^\circ$ ($\pm .21$ "/ft. or 17.5 mm/M)
Fine: $\pm 0.03^\circ$ ($\pm .007$ "/ft. or 0.6 mm/M)
- Operating Distance** L-708: Up to 100' (30.5 M)
L-708LD: Up to 200' (61 M)
- Laser Beam Diameter** L-708: < 0.25 in./6.4 mm dia.
L-708LD: < 0.38" (9.6 mm) dia.
- Beam Straightness** .00001"/ft. (.0008 mm/M)
- Beam Stability** .0001"/hr./°F (0.004 mm/hr./°C)
.0001"/ft./hr./°F (0.01 mm/M/hr./°C)
- Laser Type** Diode Laser < 0.9 mW Cw, BRH Class II
- Laser Wavelength** 670 nanometers
- Materials** Aluminum Flange. All mounting surfaces: 303 SS.

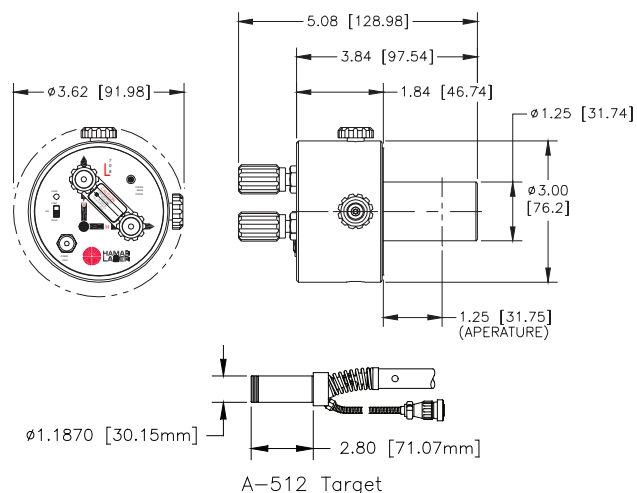

Hamar Laser Instruments, Inc.
5 Ye Olde Road, Danbury, CT 06810
Phone: 800.826.6185 • Fax: 203.730.4611
Int'l: +1.203.730.4600
E-mail: sales@hamarlaser.com
www.hamarlaser.com