

L-730 Series Precision Geometry Lasers

High-Accuracy,
Economically-Priced
Laser Alignment Systems



How Lasers Work — Principles of Operation

LASER is an acronym for Light Amplification by Stimulated Emission of Radiation. Lasers radiate in a single wavelength, in one direction and in a straight line, and are detected by position sensing detectors (PSDs). PSDs detect and convert the center of energy of the laser spot into a calibrated digital reading for output to a hand-held readout or computer interface.

Continuously sweeping laser planes are produced by bending a laser beam precisely 90° using an optical pentaprism. Hamar Laser applies a patented correction process to the pentaprisms to produce ultra-flat, continuously sweeping laser planes.

A laser plane is used for alignment by making it parallel (i.e. “bucked-in”) to 3 reference points or a datum plane, and using targets to measure deviations from those points. Once the laser is bucked in, any point within range of the laser system (up to 100-foot radius (30.5 m)) can be aligned to the reference points. If only measurements are required, software can greatly speed up this process.

Our multi-plane lasers, such as the L-733, generate up to 3 ultra-flat laser planes and can be used with multiple targets on multiple axes to check alignment in most cases with only one setup.

For most machining centers, the process begins by simply “bucking-in” the laser to 5 reference points, 3 points using the horizontal laser plane (usually on the machine’s table) and 2 using one of the vertical planes. The 2 reference points for the vertical plane are usually chosen from either the X or Y straightness motion of the machine. The horizontal plane is measured using vertically mounted targets and the vertical plane uses horizontally mounted targets. The pitch, roll and yaw of the laser planes are adjusted by using adjustment knobs built into the base of the laser.

After bucking in, the target is moved to various points along the surface where it measures deviation from the laser reference plane. For squareness, a target is placed usually horizontally on one part of the column and zeroed. The column is then traversed up or down and any deviation becomes a measurement of squareness since the laser plane used for measuring is perpendicular to the reference laser plane.

Please visit www.hamarlaser.com under How Lasers Work for more detailed descriptions.

Optional Upgrades

L-730 Series laser performance can be enhanced with the purchase of these target, accessory and software options:



R-1309 Wireless Cassiopeia Readout. Displays up to 4 targets simultaneously.



A-1519 Single-Axis Wireless Target. Measuring range of 1" (25 mm) and 0.0005" (0.012 mm) resolution.



Plane5 — Project Setup Screen. Configure shape and # of points for up to 7 surfaces.

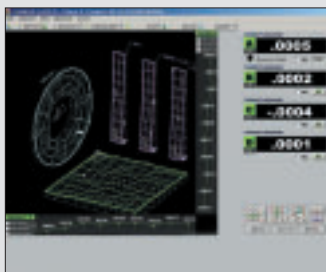

Plane5 — Plot View Screen. 3-D plot of surface flatness of 3 or more surfaces.

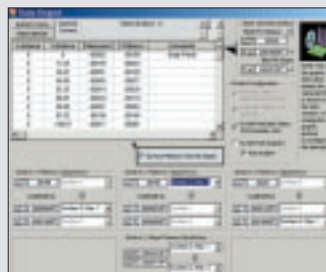

Plane5 — Report Screen. Complete report showing flatness, squareness and parallelism of all surfaces measured.



Machine Tool Geometry — Axis Setup Screen. Setup each line of motion for number of points to be measured.

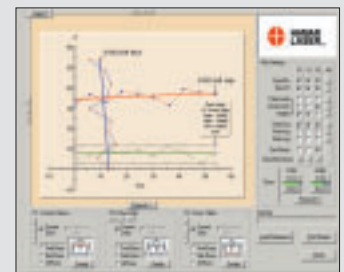

Machine Tool Geometry — Graph Screen. Shows axis TIRs, parallelisms and squarenesses between axes.

L-730 Series Features and Benefits

Hamar, the leader in laser alignment technology, introduced the world's first flat laser plane in 1974, and the first automatically sweeping laser plane in 1985. Today, no one can match our systems for accuracy, versatility, fast setup, ease of use and the quick generation of alignment data.

The L-730 Series adapts Hamar's 36 years of metrology innovation to applications with less stringent alignment requirements like fabrication alignment, steel and textile roll alignment, woodworking, and the water-jet/laser-cutting machine tool industries. You get the benefits of our high-accuracy laser systems, at a price that is easier to justify.

All L-730 Series lasers have automatically sweeping laser planes accurate to 2 arc seconds (0.00012"/ft or 0.01 mm/M), come in 1, 2 or 3-plane configurations and are equipped with built-in, backlit level vials with the same accuracy.

L-730 Series lasers feature two target options: a) The A-1530 Series with a built-in readout, up to 3" (75mm) measuring range, and 0.001" (0.02 mm) resolution, or b) the A-1519 Series with wireless communication to a PDA, up to 1" measuring range, resolution to 0.00002" (0.0005 mm) and automatic data downloading into our machine geometry analysis software.

All L-730 Laser Systems Feature:

- Live alignment data output for measuring and fixing alignment errors
- Continuously sweeping laser planes with 2-arc-second accuracy
- Lasers planes have a range of 100 feet (30.5 m) in radius
- Targets with up to 3" (75 mm) measuring area and .0005" (0.013 mm) resolution
- Multi-plane lasers have built-in squareness measuring capability of 2 arc seconds
- Dimension measuring capability with target height-gage feature
- 50% smaller and 50% lower prices than our previous models
- Simplest and quickest squareness setup on the market
- Utilizes multiple targets simultaneously for fast alignments
- Up to 60% faster alignment than optical methods
- Collect *complete* geometry data on most machines or fabrications, in 90 minutes or less
- Instant on with virtually no warm up

Alignment Advances from the L-730 Series:

- 50% smaller and 50% lower prices than our previous models
- Simplest and quickest squareness setup on the market
- Utilizes multiple targets simultaneously for fast alignments
- Up to 60% faster alignment than optical methods
- Collect *complete* geometry data on most machines or fabrications, in 90 minutes or less
- Instant on with virtually no warm up

L-730 Series Geometric Alignment Capabilities:

Flatness (Level)

- Tables and Interrupted Surfaces
- Ways and Lines of Motion
- Way, Vertical-Column and Cross-Rail Twist
- Pitch and Roll Angular Measurements

Straightness

- Ways and Lines of Motion
- Column Travel
- Beams or Other Structures
- Yaw Angular Measurement

Squareness

- Columns to Tables or Ways
- X to Y Axis, Z to X axis and Z to Y Axis
- Gantry Stagger

Parallelism

- Master Way to Slave
- A, B, C & W Axes to Main Machine Axes
- Roll-to-Roll
- Platen-Ram to Platen-Ram

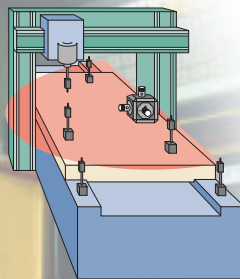

Flatness

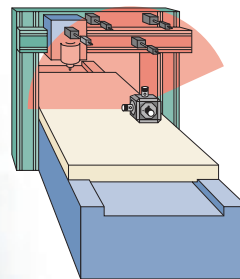

Squareness

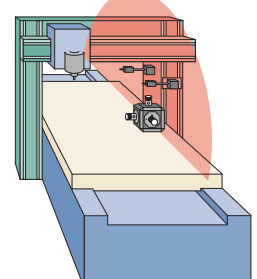

Straightness

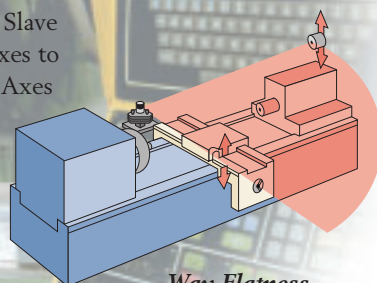

Way Flatness

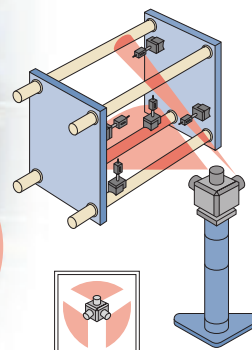

Platen Alignment and Tie-Bar Squareness

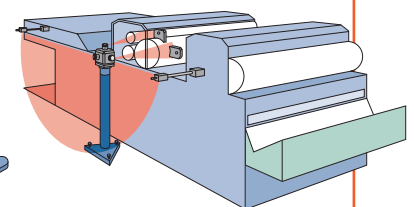

Process Mills

Multi-Plane, High-Accuracy Laser Alignment for the Fabrication Industry

L-733 Precision Triple Scan® Geometry Alignment System

Hamar's L-733 gives you the ability to complete alignment tasks in a fraction of the time required using conventional methods. The L-733 is one of only two lasers in the world — both made by Hamar — to offer three automatically rotating laser planes so you can measure flatness, straightness and squareness simultaneously, with just one setup.



Model L-733 Basic Package for Machining Centers

The L-733 features accuracies of 2 arc seconds for flatness and squareness, and comes with backlit level vials accurate to 2 arc seconds. Add wireless targets — with built-in displays, or wireless data transmission to a hand held readout device — and you have an extremely powerful and versatile alignment tool.

With one simple setup, you can:

- Measure flatness and straightness of machined surfaces, bed ways and columns
- Check squareness between axes or surfaces
- Determine parallelism between vertical and horizontal surfaces, axes or rolls
- Set specific dimensions or elevations of horizontal or vertical surfaces by using the height gage feature of our targets.

The IR wireless target upgrade allows you to transmit data to a computer for comprehensive analysis using our easy-to-use analysis software. Machine Tool Geometry or Plane5 software can record and analyze flatness profiles, then produce 3-D color graphs of the misalignment condition.

L-732 Precision Roll Alignment System

Roll alignment has never been easier than with the L-732 Roll Alignment System. Unlike other “point and shoot” laser alignment systems, the L-732 offers two automatically sweeping, ultra-flat, orthogonal laser planes. This significantly reduces setup and alignment times, and vastly simplifies the overall process.



Model L-732 Roll Alignment Package

Add to it, our wide-range wireless targets, 1 arc-second electronic level for leveling the rolls, factory-made benchmark reference fixtures and you have a system that helps you align rolls in record time. And the increased system accuracy over conventional optics means roll alignments will be better than ever. Better alignments mean lower scrap rates, potentially higher throughput and lower startup costs after outages.

The L-732 can easily and quickly:

- Check and correct horizontal roll parallelism of even the tallest process mills
- Pick up and check offset centerline benchmarks
- Level the rolls with our new A-700 Electronic Level
- Perform other similar alignments in record time

The L-732 is so easy to use that it requires only 2 days of training with most trainees becoming proficient after the second or third use.

L-730 Series Applications



Fabricating Machinery Applications:

- Roll-Forming Machines
- Tube-Bending Machines
- Routers
- Water Jet Machines
- Laser-Cutting Machines
- Woodworking Machines
- Saw Mills



Fabrication Alignment Checks:

- Truck Bed Assembly
- Agricultural Machinery Assembly
- Large Construction Machinery Assembly
- Locomotive Assembly
- Fire Truck Assembly



Economical, Single-Plane Lasers for High-Accuracy Leveling and Squaring

L-731 Precision Leveling Laser with Plumb Beam

For those with lower budgets but high-accuracy needs, L-731 Precision Level Scan Laser offers the ultimate in accuracy and affordability. The laser has a single automatically sweeping laser plane that is flat to 2 arc seconds and a plumb laser beam that is square to the laser plane to within 2 arc seconds. It also features 2 backlit, 2-arc second level vials for precision leveling applications.

The system uses a combination of wireless single-axis scan targets and 2 or 4-axis, straight-line-laser targets to offer simple setups and high accuracy for such applications as:

- Flatness and straightness of machined surfaces, machine ways and tables of most machining centers and large-bed lathes
- Flatness and straightness of vertical axes or surfaces
- Squareness of vertical axes to horizontal surfaces
- Parallelism of 2 vertical surfaces or axes
- Parallelism of horizontal surfaces

Upgrade to our wireless targets (A-1519) and our Machine Tool Geometry or Plane5 software and you have a very affordable machine tool alignment package that cannot only document alignment errors quickly, but also can fix those errors, using the targets as digital indicators. The L-731 is also very portable making it an ideal entry-level geometric alignment system.

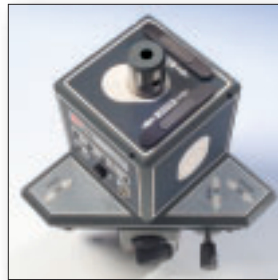

Model L-731 Laser

L-730 Precision Leveling Laser System

The L-730 Precision Leveling Laser System is an affordable, accurate, easy-to-use flatness measuring and leveling system. The laser plane is flat to 2 arc seconds, has a range of 100' (30.5 meters) in radius and features 2 backlit level vials accurate to 2 arc seconds. The continuously rotating laser plane, combined with our wireless targets, allows you to measure, adjust, or monitor multiple points simultaneously.

The L-730 is probably the simplest alignment tool on the market for:

- Checking the flatness of almost any surface (squares, frames, ways, flanges, circles, etc.)
- Measuring and leveling machine beds and ways, large bearing surfaces, and fabrications
- Checking way twist and parallelism between horizontal surfaces
- Measuring surfaces up to 200 feet (61 meters) long with 1 setup

It is so simple to use that it only requires 1 day of training, including calibration!

Taking measurements is easy: Simply level the laser, place a target on one point of the surface, and then "zero" it. To perform corrections, place the target over an adjustment point and turn the bolts while watching the readout update automatically.

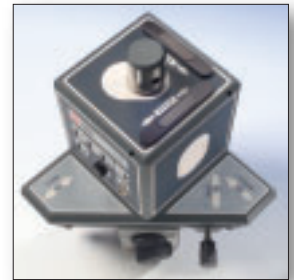

Model L-730 Basic Leveling Package

Roll Alignment:

- Steel Mills
- Aluminum Mills
- Textile Mills
- Food Processing Mills



Aerospace Applications:

- Body-to-Body Join Assembly Alignment
- Seat-Track Alignment
- Aircraft Interior Alignment (Storage Bins, Gallies, etc.)
- Wing-to-Body Joining Alignment
- Floor Beam Alignment
- Jig/Tooling Calibration and Leveling



Ship Building Applications:

- Hull Construction
- Section Alignment and Layout
- Elevator Shaft Alignment
- Periscope Shaft Alignment
- Gun-bearing Alignment

Specifications

L-733 Triple Scan Laser with Coarse Adjust Base

Weight	Laser: 3 lbs. (1.3 kg) Base: 4.8 lbs. (2.2 kg) Battery Pack: 1 lb. (0.45 kg)
Material	Laser: Aluminum and stainless steel Base: Aluminum
Laser Type	Class II visible diode, 635 nm wavelength (class 1 in Scanning Mode); 0.160" (4.06 mm) beam diameter
Beam Power	0.9 mW per straight beam
Beam Stability	.0001"/hr/°F (0.005 mm/hr/°C) translational 0.2 arc sec./hr/°F (0.36 arc sec/hr/°C) angular
Beam Straightness	0.00001 in/ft (0.0008 mm/M)
Laser Plane Flatness	360° Sweep: 2 arc seconds (0.00012 in/ft or 0.01 mm/M), plus maximum translational error of +/-0.0001" (0.0025 mm) 90° Sweep: 1 arc second (0.00006 in/ft or 0.005 mm/M) plus maximum translational error of +/-0.0001" (0.0025 mm)
Beam/Plane Squareness	3 planes mutually square to within 2.0 arc seconds (0.00006 in/ft or 0.005 mm/M)
Operating Range	100 feet (30.5 meters) in radius
Operating Modes	1, 2, or 3 beams and/or 1, 2, or 3 continuously sweeping planes in any combination, individually switched
Power Supply	9V DC external battery pack (4 cells) or 115V AC adapter
Power Draw	(See chart)
Adjustment Range	+/- 3 degrees
Adjustment Resolution	0.010" (0.25 mm) in 100 feet (30.5 meters)

L-733 Precision Triple Scan® Laser

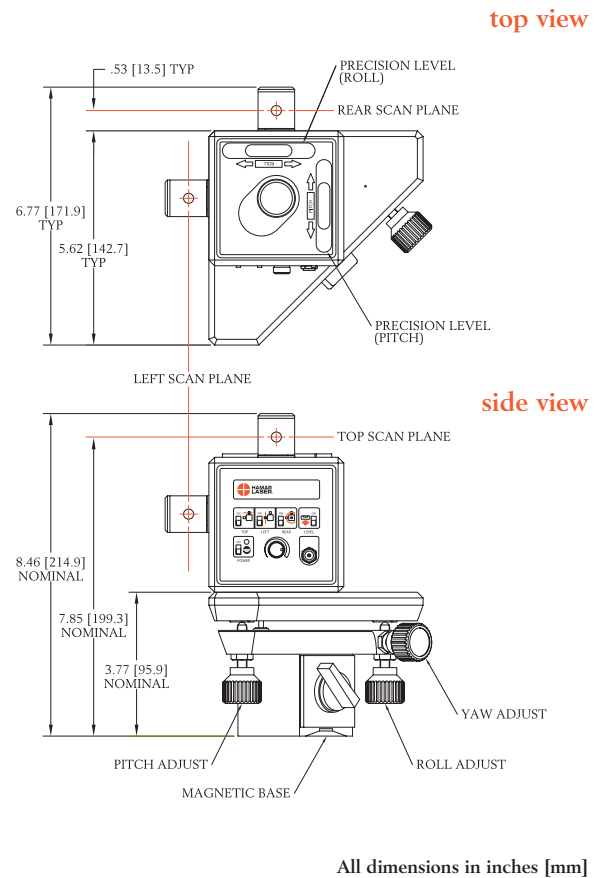

Power Draw	Laser Only	Laser & Scanner	Battery Life*
1 Beam	100 mA	130 mA	2.5 hrs.
2 Beams	180 mA	230 mA	1.4 hrs.
3 Beams	260 mA	330 mA	1.0 hrs.

* Per 9V alkaline battery (500 mA hrs.). Multiply battery life figure by the number of batteries used (external battery pack uses 4 cells).



Universal Targets
Large measuring ranges, built-in displays, medium resolution.



L-106 Instrument Stand
Lightweight, variable-height stands for flexible setup.



Hamar Laser Instruments, Inc.
5 Ye Olde Road, Danbury, CT 06810
Phone: 800.826.6185 • Fax: 203.730.4611
E-mail: sales@hamarlaser.com
www.hamarlaser.com